

AIS-Module 400

Installation Manual

AIS-Module for: AS 40P, AS 4000, AS 100 IT

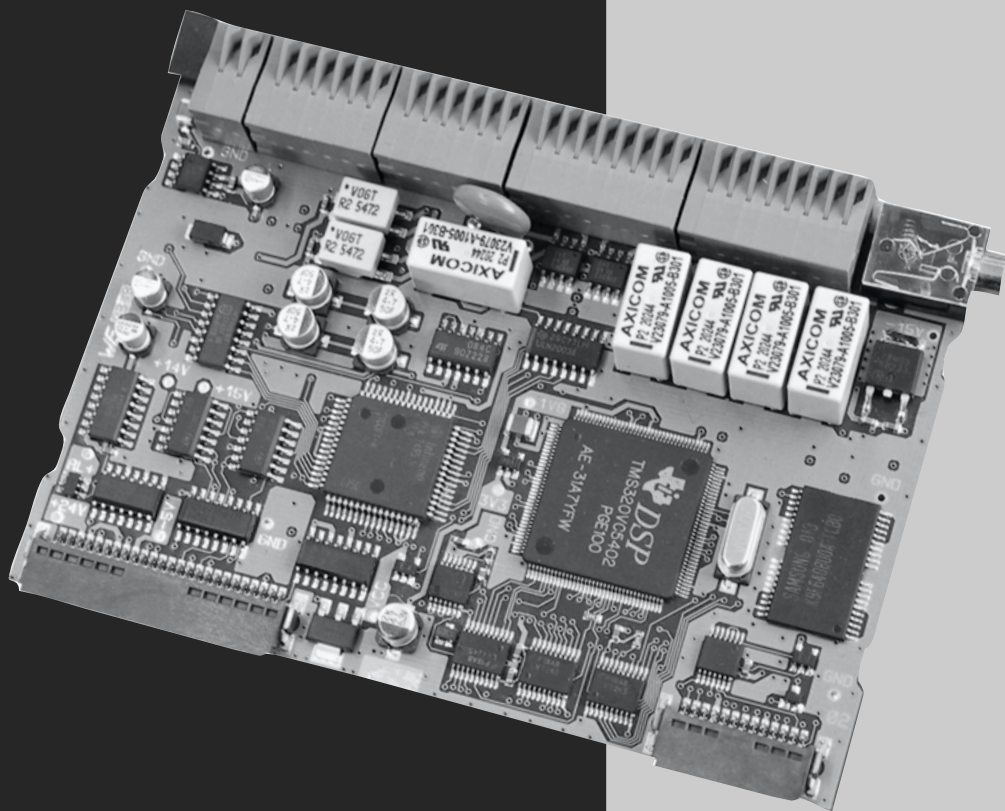

AGFEO

einfach | perfekt | kommunizieren

About this manual

These instructions apply to the version as shipped. Should the Manufacturer offer new features within the software, then some of the instructions as featured in this manual may be invalid.

Table of contents

About this manual	2
Introduction	4
System requirements	4
Included products	5
Safety precautions	5
Connections of AIS-Module 400	6
Doorphone Installation	7
Doorphone Connections	7
Sensor Inputs	8
Configuration	8
Music on Hold (MoH)	10
Door Messages / Door Bell	12
Sensor Announcement	12
Wake-Up Alarm Message	12
Time	13
Music on Hold	13
Greeting / On-Hold Message	14
“Message before Answered by Group”	14
Extension / Group Ringing	15
Call Mode	16
Play Message	16
Message and Ringing Sequence	16
Announcement during Ringing	16
Assignment of Message	16
Assigning On-Hold-Messages	17
Door-Phone-Messages	17
Sensor Messages	18
Record messages via ST 30	19
Sensor Settings	20
Reset Sensor after detection	20
Sensor activation	21
Sensor notification	21
Alarm message for sensor settings	22
Sensor Timers	23
Sensor Settings – Sensor Names	24
Sensor Test	25
Sensor Activation / Deactivation using the function key	25
Activating / Deactivating the Sensor using the Telephone	26
Querying the Sensor using the Telephone	26
Wake Up Call	27
Load Wavefiles into ST 30 with TAM Module	28
Declaration of Conformity	29
Copyright	30
Technical modifications	30
Copyright Free Music	31

AIS-Modul 400

Introduction

You can expand your system by adding an Audio Information System, the AIS Module 400. The AIS module will enable you to integrate individual messages and Music on Hold into the system. You may activate an announcement for up to two callers simultaneously to be played before the call is answered, or only if the operator or extension is busy.

The "Message prior to answering" function can be used for 2 external lines, and can be configured to provide the caller first with a message prior to connecting, or to deliver the announcement in the event of a busy user or group.

Individual Music on Hold can be played using the AIS Configurator.

In default the AIS module has pre-recorded with Music on Hold and announcements.

The AIS-Module 400 can hold up to 35 minutes of audio files. In default 11 Minutes are used with pre-recorded messages. Audio files may be used to play information, promotional messages or music.

For musical recordings please observe relevant copyright laws

In addition, the AIS-Module 400 provides you with a 2-wire - and a 4-wire doorphone connection. 4 input contacts which will support the connection of commercial alarm sensors or movement detectors with 12 V supply are also available.

With the AIS Configurator you can select individual .wav files or converted MP3 files and assign them to different message types, for example, greeting, music-on-hold, door, sensor and wake-up

alarm. You can create these .wav files yourself or obtain them from commercial sources (see standard tunes). Please note, that these wavefiles must use standard PCM format, 8 or 16 Bit, mono or stereo in sampling rates from 6 to 48 KHZ. These files have to be audiofiles without additional headers (copyprotection).

Wake-up alarm times can be set from individual telephones by using the keypad. At a specified time you can receive a call with a message, for example "This is your wake-up call. The time is ..."

If a door contact or other sensor is connected to the telephone system then an internal or external call can

be initiated to a preset telephone number, once the sensor has been triggered, and deliver a spoken message.

You may assign a message to such calls, for example "Sensor door one has been activated."

Calls from a door phone may be signalled by playing different tunes, using audio files.

System requirements

Installation of the software package requires the following system components.:

- AGFEO ISDN TK System AS 40P, AS 4000, AS 100I T (all Version 6.0 or above)
- IBM or compatible PC with hard drive and CD-ROM drive
- Pentium II or better
- Minimum of 64 MB RAM
- Microsoft Windows 98/2000, ME, NT 4.0 or XP
- ISDN adapter (e.g., internal ISDN card)
- Sound card, microphone and speaker (optional) to record or listen to audio files on the PC (optional)

AIS-Modul 400

Included products

- | | |
|--|---|
| 1 AIS-Module 400 | 4 Termination resistors 12,1 KOhm |
| 1 Set up and operating / installation instructions | 1 TK Suite software package with AIS Configurator |

Safety precautions

1. Unplug the system from the 230V mains supply.
2. Unplug all external ISDN lines from the telephone system.
3. Briefly touch the metal cover of the PC printer connector on the bottom of the phone system, this will discharge any static electricity which might damage components of the phone system.

Installation of AIS-Module 400

Remove the module from the packaging

SAFETY PRECAUTION

Prior to removing the module from the packaging and installing it into the telephone system, briefly touch your finger to the metal cover of the PC / printer connector on the bottom of the telephone system. This will discharge any static electricity which might damage the components of the TK system.



The AIS-Module 400 can only be used in SLOT 4 of your AGFEO PABX System

AIS-Modul 400

Commissioning

Please close the cover again!

Switch on the telephone system, by plugging the 230 V mains plug into the socket.

After receiving the system programming via TK-Suite Set you will see under 'Telephone System / Hardware / Configuration' that the AIS Module is being displayed as installed.

Connections of AIS-Module 400

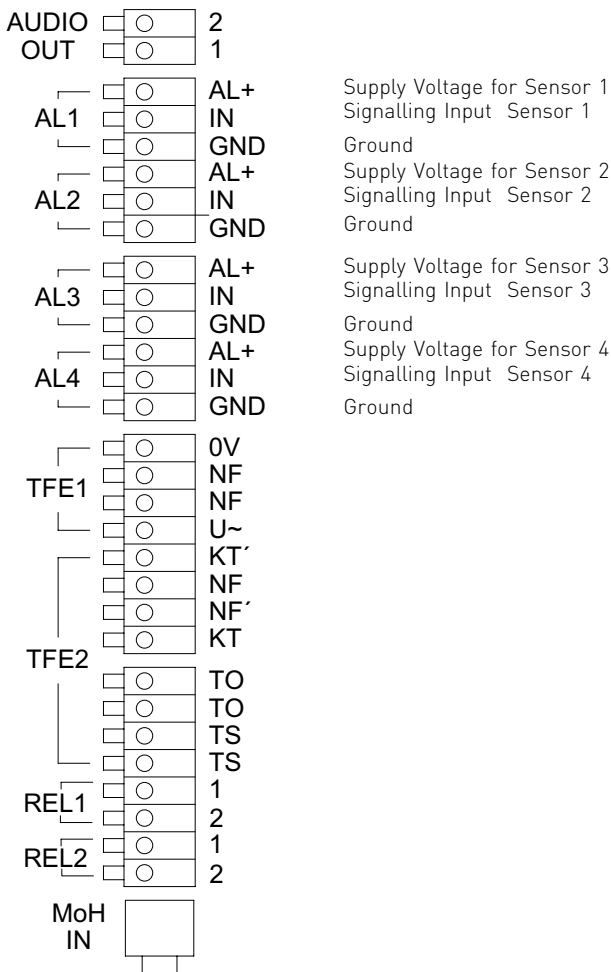

AIS-Modul 400

Doorphone Installation

The AIS-Module 400 has connections for doorphones to the 2 wire standard. This connection supports 4 bell pushes. In addition, it has connections for doorphones with built in amplifiers to the 4 wire standard FTZ 123 D 12. The system will support one bell push per connection. (Further information regarding doorphone connections are available by visiting our website on www.agfeo.de)

Doorphone Connections

Connections:

- Contacts KT1 and KT2 are for the connection of a Bell Push
- Connection of a DC free speech circuit of either a doorphone or Tannoy system on NF1 and NF2.
- Electric door release via the relay contacts TO. Max load 30 VDC / 1A. Note: You will need a bell transformer to activate the lock release
- Doorphone control via the relay contacts TS. Max load 30 VDC / 1A

Connecting Cable:

- Strip 11 mm of the wire
- push the wire all the way into the connection block without pressing the release catch.
- to disconnect a cable, press the release catch with a small screwdriver and pull the wire out of the connection block

For installations not within the building parameter we would advise the installation of surge protectors.

Should you need further bell pushes, then you may use the sensor inputs of the AIS-Module 400.

- NF1, NF2 = DC free speech circuit
- KT, KT2 = Bell Push connection
- TO = Dooropener-Relay
- TS = Relay to activate external amplifiers

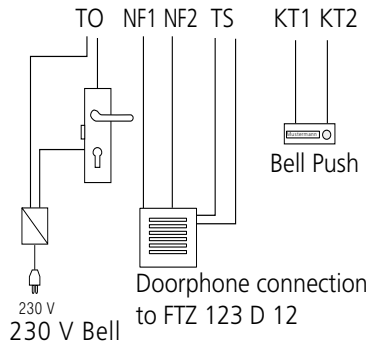

Transformer for Dooropener

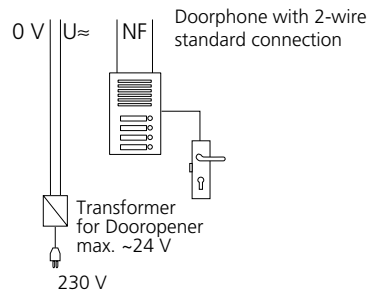

AIS-Modul 400

Sensor Inputs

You may connect sensors to the AIS-Module 400 which have normally closed or normally open contacts. Power for sensors can also be supplied via the telephone system. Max 12 V and 200 mA. Due to differential inputs you may connect a mixture of contacts. (Connection see illustration) The last contact must be terminated with a 12,1 k Ohm Resistor. (Included in pack).

Alternatively you may trigger these circuits like bell push contacts. Please note that the type of connection will not be changed. (with termination resistor)

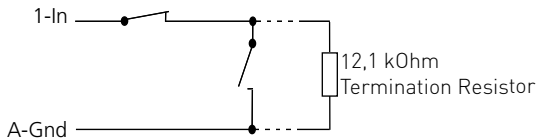

Configuration

After you have installed the AIS module and have programmed TK Suite Set, start the AIS Configurator. Click on the "Read system" button, the AIS data is read out from the phone system. Please make sure that the AIS Configurator links to the system via the X.31 protocol. If you are using TK Suite Basic with a permanent X.31 connection, you have to close TK Suite Server in order to use the AIS Configurator.

The AIS Configurator will offer various messages as well as editing fields.

In the Profile pane, you can:

- Load an existing AIS configuration
- Save a new AIS configuration
- Create a new configuration

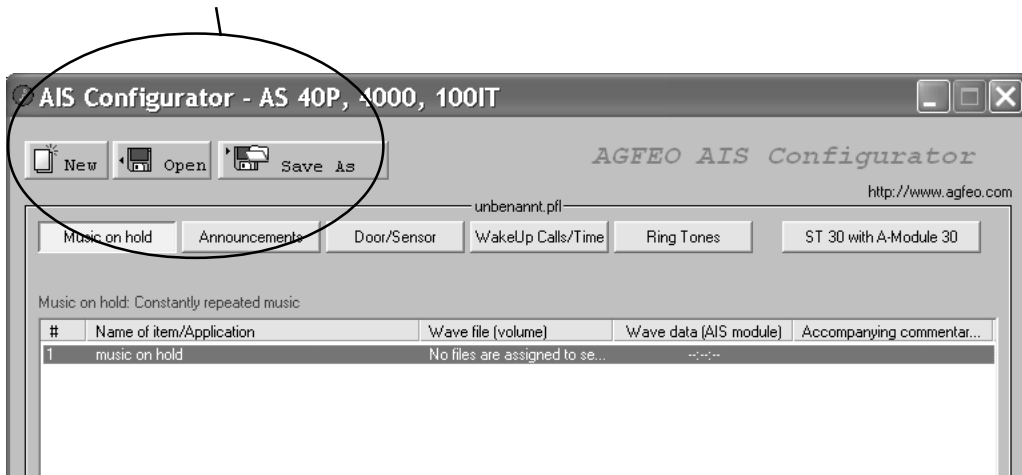

AIS-Modul 400

Configuration

If you click with the right hand mouse onto an entry, a context menu will open.

In this menu you may select the following:

- select wave file on PC, to be allocated to the AIS Module
- listen to selected WAV file
- delete the selected entry
- enter or delete a comment
- send selected wave file to the system
- delete a wave file in the system
- read out a wave file from the system
- check a wave file in the AIS Module

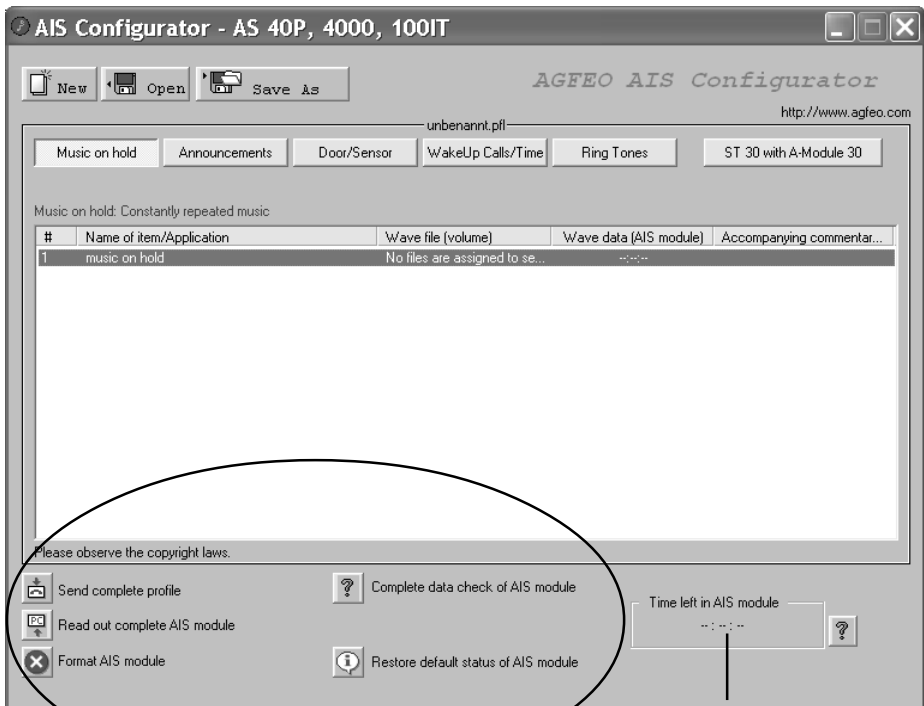

This line displays the available AIS system storage in seconds

In the Communication pane you can:

Select a .wav file on your PC (an index must be highlighted for this)

Send a new AIS configuration to the system

Delete an existing AIS configuration in the TK system.

Read out an AIS configuration from the system.

You can change a comment in the message pane by double-clicking with the left mouse key which activates the editing mode.

Loading .wav files into the TK system can be done either using the internal S0 bus.

AIS-Modul 400

Transferring Messages and Music-on-Hold

Music on Hold is automatically integrated into your TK system when you install the AIS module. The Music on Hold can be replaced at any time using audio files. This is how you do it.

Music on Hold (MoH)

Audio files allow you to create pleasant on-hold music to be played while a caller is on hold or is transferred to another extension.

Changing Music on Hold

Click on the Music on Hold button. The following appears in the input screen:

Index	File name	Comment
Music on hold1	Name	Comment

Highlight the line Music on hold1.

You can listen to available .wav files using the "Listen to .wav file."

The "Select .wav file" button allows you to select .wav files stored on your PC and transfer them to a tagged location using the "Open" function.

By clicking on the "Change comment" button, you can enter a comment or a title; the change is applied using the ENTER key.

When you change a comment, you must first highlight the field (line) you wish to change.

Please note:

Music on Hold must be activated in the TK Suite Set configuration program in the pane "Additional settings" under "Music on Hold."

Please follow current copyright laws when using music selections.

Messages Greeting

The greeting announcement is played to external callers before they are connected to one of the groups you have defined. For example, the greeting might be used for marketing purposes. As soon as an external call is put in a "Message prior to answering" queue, a seasonal message might be played, for example, "Winter is coming up. Time to think about snow tyres."

You can also define whether calls for the group always hear the message, or only if all extensions within the group are busy. You may also specify whether the greeting is played in its entirety before the call is answered, or whether the call can be answered during the message playback. If group members are called according to your call distribution, a call can be picked up during the announcement.

Applying greeting messages

Clicked on the button "Greeting message." The following appears in the input screen:

Index	File name	Comment
Message 1	Name	Comment
Message 2	Name	Comment
.....to	:	:
Message 10	Name	Comment

Highlight Line 1, for example.

The "Listen to .wav file" button allows you to listen to the .wav file (if available).

The "Select .wav file" button allows you to select .wav files stored on your PC and transfer them to a tagged location using the "Open" function.

By double-clicking on a line (e.g., "Message 1") you change to edit mode, allowing you to change the comment. "ENTER" applies this comment.

On-Hold-Message

When an external caller has received the greeting and has been transferred to the "Message prior to answering Group," the extensions are called according to their notification type. During this ringing phase, you may specify whether the external caller receives an on-hold message (e.g., "Your call is being transferred") or hears ringing tone.

Applying an on-hold message:

Follow the same procedure as for "Applying greetings." Just click on the "On-hold message" button.

AIS-Modul 400

Door Messages / Door Bell

To make it easier to identify calls from the door, you may use audio files to provide individual sounds (such as a door bell). These are output via the speaker.

Please note:

The speaker must be assigned an internal extension number; this is set up in the TK Suite Set under "Additional Settings."

In the pane "Doors, Relays and Sensors," you can assign door signal distribution and register the speaker with its internal extension number.

Applying door messages / signals:

Follow the same procedure as for "Applying greetings." Just click on the "Door messages / signals" button.

Sensor Announcement

Depending upon the basic setup of your telephone system, there are two contact inputs /sensor inputs which may be used to connect typical alarm sensors or motion detectors. You may store sensor announcements (e.g., Sensor entrance 1 has been activated); an activated sensor may, depending upon your settings initiate an internal or external call. When you accept the call, you will hear the sensor announcement.

Applying a sensor announcement:

Follow the same procedure as for "Applying greetings." Just click on the "Sensor announcement" button.

Wake-Up Alarm Message

Each telephone system extension may set an individual wake-up alarm time. At the specified time, the telephone rings and a pre-recorded message is played.

If you use the AIS Configurator, two sample alarm messages are provided as examples.

Alarm 1 - Announcement before the time This is your wake-up call. It is xx o'clock.

Alarm 2 - Announcement after the time Have a nice day

Between the messages for Alarm 1 and Alarm 2, the current time is announced. You may, however, provide your own announcements for Alarms 1 and 2. These messages are automatically used for a wake-up call.

Applying the Wake-up alarm announcement

Follow the same procedure as for "Applying greetings." Then just click on the "Wake-up alarm message 1 / Wake-up alarm message 2" button.

AIS-Modul 400

Time

As described above, the current time is automatically announced between Alarm Message 1 and Alarm Message 2.

If you create your own wake-up Alarm Message, the time is announced using the stored system voice.

If you would rather use a different voice, you may record the individual times using .wav files.

Applying the current time

Follow the same procedure as for "Applying greetings." Just click on the "Time" button.

Settings in TK Suite Configurator

A few additional settings in the TK Suite Set configuration must be adjusted to allow you to use the AIS module and .wav files in the AIS configuration. These are described below.

Music on Hold

The following pane is on the page "Special functions - additional settings:" On-hold music (Music on Hold) with the setting options:

Off (MoH is turned off)

AIS (The AIS module MoH is used)

External source (MoH relies on an external source, such as a CD player)

Select the desired MoH type by first by clicking on the type, and then by clicking on the on the "Send" icon.

The screenshot shows the TK Suite Configurator software interface. The main window title is "TK-Suite" and the application name is "AGFEO". The interface is divided into a left sidebar with a tree view of settings categories and a main content area on the right. The "Music on Hold" settings are currently selected in the sidebar. The main content area displays a list of settings with their current values and a "Send" button for each setting.

Setting	Value	Send
Music on Hold	AIS-Module	[Send]
Volume for MOH	4	[Send]
Park (play) with Code	[]	[Send]
Did 99 instead of *#	[]	[Send]
Sub-PABX Prefix	[]	[Send]
ISDN Number Format - National Number	[]	[Send]
AIS and Acoustic Settings		
Speaker Extension Number	200	[Send]
Speaker Output Volume (e.g. Door Bell)	4	[Send]
Play external MOH through Speaker Output (e.g. Waiting Room)	[]	[Send]
Time-Settings		
Call return after transfer (secs.)	45	[Send]
Paralleled call return (secs.)	240	[Send]
Diversion on no answer (secs.)	15	[Send]
Automatic dial (secs.)	10	[Send]
Time between redials (secs.)	90	[Send]
Time of diversion of hunt groups (secs.)	15	[Send]

Greeting / On-Hold Message

Various settings can be adjusted in the configuration page "Internal Numbers - Define Groups." The AIS -Module allows a message to be played before the call can be answered. A message can be played for up to two callers simultaneously. You can also change the settings for two group numbers.

"Message before Answered by Group"

Open the configuration page in the TK Suite Set Configurator "Internal Numbers – Define Groups"

and set the Hunt Group number with its extensions, the call mode and ringing for group members.

Once you have established a Hunt Group number with extensions, then the following symbols will appear above the members of the group:

A) By clicking on this button, you will see all extensions who are a member of a group.

B) By clicking on this button you may rearrange the ringing order of the selected extensions. This is important in the event that a member of the group logs out of the group. Once the extension has logged in again, the old position in the group is resumed.

C) By clicking on this button, selected extension may log in or out of the group.

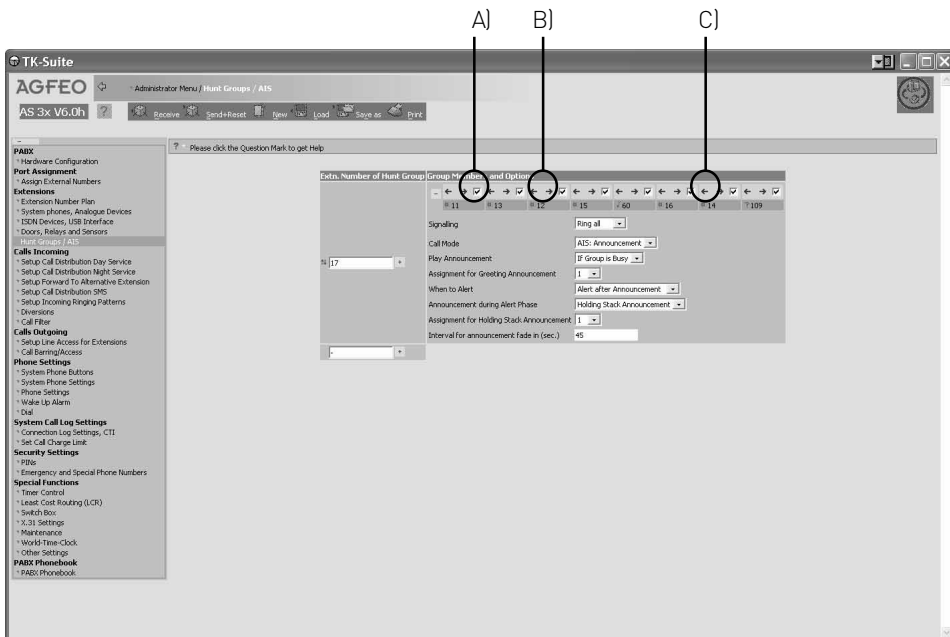

Extension / Group Ringing

In the drop down list you can set the following extension ringing.

Ring all: an incoming call will ring all extensions simultaneously.

Fixed Port: Ringing will always start at the first extension within the group. If the call is not answered then it will go to the next programmed extension within the group. The call will remain ringing at the last programmed extension if no one has answered the call.

Sequential: ringing will always start with the first entry in the group. If the call is not answered then the next extension in the group is added to the already ringing one. This pattern will continue until all extensions in the group are ringing. Ultimately all extensions will ring until the call is answered.

Circular means that ringing will start with the first extension in the group. If the call is not answered then it will go to the next extension within the group. If the call remains unanswered at the last extension, then it will start at the beginning of the group again.

Notification

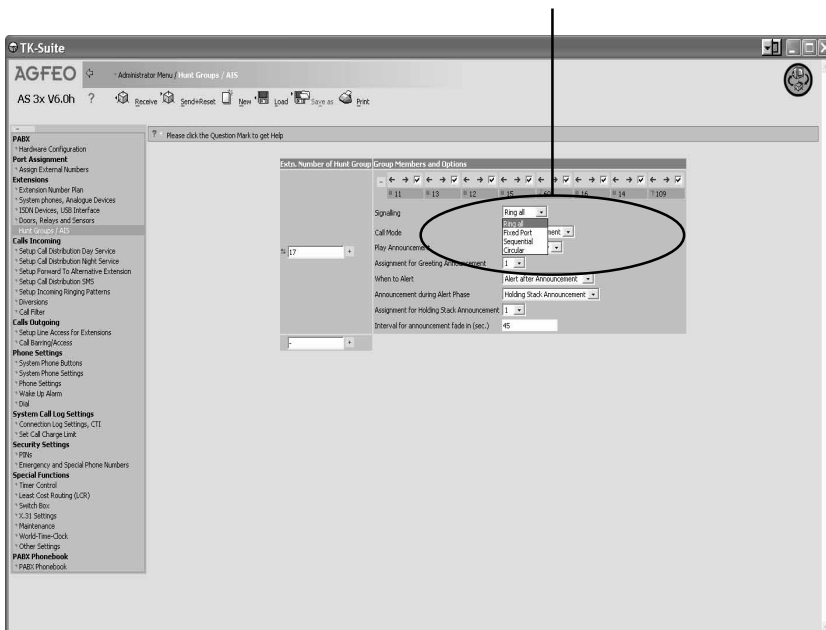

AIS-Modul 400

Call Mode

In the setting Call Mode you can select how a call should be answered, ie by the AIS Module. As soon as you make this selection from the drop down list, further options will be offered.

Play Message

under "Play message" you can specify whether an external call to a hunt group number is

- "Always" answered automatically with the greeting or
- "Only when the group is busy."

Select the setting.

Message and Ringing Sequence

On an incoming call, the caller will receive the announcement as set in play message. You now can select if the hunt group should ring:

- after the announcement-

The caller will hear the announcement to the end before the hunt group is rung.

- or-
- during announcement-

The caller will hear the announcement but at the same time the hunt group is rung. If a member of the hunt group answers the call then the announcement will stop. Select your setting.

Announcement during Ringing

After a caller has listened to the recording and the hunt group is being rung you may select if the caller receives a

- Ringing Tone-
- or a reassuring message, which can be a spoken message with background music, such as 'Please hold your call is being transferred' or 'Your call is important to us etc.

Please select the type required by clicking on it.

Assignment of Message

There are several greeting messages stored in the AIS Configurator under "Messages." These stored announcements have index numbers (1-10) as well as a comment for easy identification. Select the desired message by clicking on it.

Assigning On-Hold-Messages

Under "Messages," various on hold messages are stored in the AIS Configurator. These stored announcements have index numbers (1-10) as well as a comment for easy identification. Select the desired message by clicking on it.

Door-Phone-Messages

Depending on the basic configuration of your telephone system, there are 2 contact / sensor inputs in the configuration page "Doors, Relays and Sensors."

The following settings can be configured:

Operation type:

You can set the operation type "Door" by clicking on it.

Once you have set this operation type, various configuration options for the door are provided in the Option box.

Internal calling number for door: = Extension number for the door

Specify a free internal calling number for the door. = Select a free extension number for the door.

Call Distribution Day Service

Select the extension number which should ring when the door bell is pressed. Also tick the box to activate this setting.

Call Distribution Night Service

Select the extension number which should ring when the door bell is pressed. Also tick the box to activate the night service setting.

Set Up Incoming Ringing Patterns

You can assign a special ringing sequence to the door phone. In this way a door phone call will be easily identifiable.

Door / sensor message: = Door Sensor Message

There are several messages stored in the AIS Configurator under "Messages." These are listed by an index number. Select the desired message ("1" corresponds to the door / sensor message with the index number 1 in the AIS Configurator) by clicking on it.

Night is active:

By clicking on this button you can activate this setting for Night Service.

If this setting is active, then a visitor at the door will receive a recorded message after the bell push is pressed. Extension which are set for Call Distribution 1 Day, or Call Distribution 2 Night will ring when the Bell Push is pressed.

External call:

Under the external call option, you can enter an external number to be called when the someone rings the door bell.

External call:

The external call can be activated / deactivated by clicking on the button.

Sensor Messages

On the "Doors, Relays and Sensors" there are 2 sensor inputs available, depending upon the basic configuration of your telephone system. The settings are adjusted in the following panes.

Configuration:

By clicking on this you can configure the sensor operation.

Once you have selected "sensor" you are offered settings for the operation of the sensor.

Active:

By clicking on this button the sensor is activated / deactivated.

Sensor extension number:

This specifies the available extension number for the sensor.

Call variant 1:

Here you enter the internal number to be called in the event the sensor is triggered and Call variant 1 (day) is active.

Call variant 2:

Here you enter the internal number to be called in the event the sensor is triggered and Call variant 2 (night) is active.

Ring Rhythm

The call triggered by a sensor should have a special ring cadence. This way you will be able to identify a call from a sensor.

Selecting sensor message text:

There are also sensor messages stored in the AIS Configurator. These are listed by index number. Select the desired message by clicking on it.

Night is active:

By clicking on this button you can turn Call variant 2 (night) on / off.

External call:

Under the external call option, you can enter an external number to be called when the sensor is triggered.

The external number is dialled in addition to the selected extension number and has priority over calls in progress.

External call active:

The external call can be activated / deactivated by clicking on the button.

AIS-Modul 400

Record messages via ST 30

It is possible to record all texts from the System Phone.

Enter programming mode:
Select the type of text you want to record.

- 1= Door / Sensor Announcement
- 2= Announcement before Answer
- 3= Bell Push Announcement
- 4= Wake Up Announcement

Select announcement type, you can listen to this by pressing "OK".

Press "OK" again if you want to re-record the announcement.

ST 20/ 25

ST 30

DECT 30

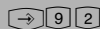

Sensor Settings

Times for sensor messages can be defined in the sensor settings view.
The following times can be specified.

Time to initiation (0-9 min):

Interval between initial sensor signal (window contact opened) until the system will recognise this.

Duration of notification (1-30 min):

This is how long the alarm lasts.

Time to external call (0-9 min):

This is the interval between the initiation of the internal alarm and the triggering of an external call.

Time to activation (0-9 min):

The time frame between activation of the sensor via the telephone until the alarm has been set.

Lock-out time or Re-arming (0-30 min):

This is the time frame until a new sensor signal is processed.

On the configuration view "Security features - codes"

you can define the alarm PIN. Your alarm PIN will be required to reset the system after a sensor activation.

You can activate /deactivate the sensor using the TK Suite Set configuration program, or via the telephone or timers.

You may also set all settings using the system telephone.

Reset Sensor after detection

Once a sensor has been triggered, the extension are called as entered in the call distribution (entered under "Doors, Relays and Sensors").

Telephones may ring with a specific call rhythm. If you have set up an alarm PIN and pick up the receiver on a telephone that has been called, you will hear the sensor message (or a special dial tone if you have not installed the AIS module); other extensions will continue to ring until the sensor alarm has been switched off. By entering the alarm PIN (during the call), you can clear the sensor alarm.

If you have not set up an alarm PIN, the sensor is deactivated when the call is terminated.

Once the specified "lock-out" time (time until the sensor is re-armed) has elapsed the sensor can be re-activated.

AIS-Modul 400

Sensor settings using the system telephone

Sensor activation

Programming:

Using the arrow keys you can select which sensor or sensors are to be activated.

With the arrow key select which sensor(s) should be switched on / off, and apply this setting with OK. After activation, you will receive the message "Sensor nn initialized 05 min until the sensor is active." The telephone transmits an intermittent signal until the sensor is activated. An "S" blinks in the display of all system telephones. The time interval will depend upon the "Time to activation" setting.

ST 20/ 25



ST 30



DECT 30



Sensor notification

Night setting:

Programming:

Sensor notification night setting activate / deactivate

The configured sensors are displayed

Select a sensor and confirm with OK.

Select whether the night setting should be activated / deactivated and confirm with OK

External routing:

Programming:

Activating / deactivating external routing of the sensor call for each sensor.

Select whether the night setting for external routing should be activated / deactivated and confirm with OK

Select whether the night setting for external routing should be activated / deactivated and confirm with OK

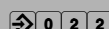
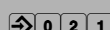
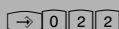
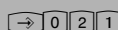
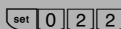
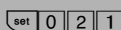

AIS-Modul 400

Alarm message for sensor settings

You can also record a message for the sensors using a system telephone.

Programming

Select the desired sensor and confirm with OK.

Pick up the receiver and you will hear a stored message.

Using the OK key you can record a new message; speak your message; end recording with OK.

Repeat this procedure to check a recorded message.

Then either select another sensor or end the menu with "Set."

ST 20/ 25

ST 30

DECT 30

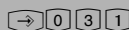
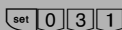

AIS-Modul 400

Sensor Timers

You may set various timers, the same as in TK Suite.

Time to active:

Time from activating to arming the sensor.

Programming

Using the numeric keypad, enter the desired single digit time, from 0 to 9 minutes

Finish programming

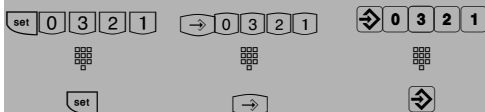

Time to triggering:

Time between detection and notification in system

Programming

Using the numeric keypad, enter the desired single digit time, from 0 to 9 minutes

Finish programming

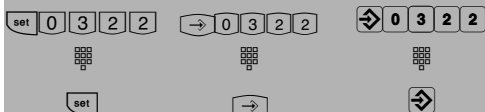

Time to external call:

Time from internal notification until an external call is made

Programming

Using the numeric keypad, enter the desired single digit time, from 0 to 9 minutes

Finish programming

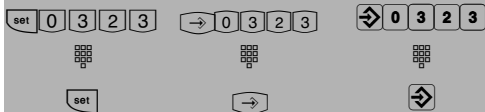

Alarm duration:

Length of time alarm lasts

Programming

Using the numeric keypad, enter the desired double-digit, from 0 to 30 minutes

Finish programming

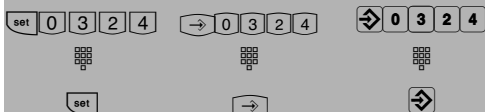

Lock-out time or Re-arming:

Time before another sensor signal can be processed

Programming

Using the numeric keypad, enter the desired double-digit, from 0 to 60 minutes

Finish programming

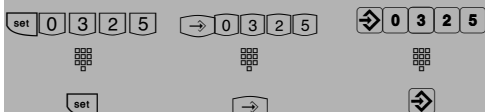

AIS-Modul 400

Sensor Settings – Sensor Names

You may assign names to the sensors Programming

Select the desired sensor and confirm with OK.

Using the numeric keypad, enter the name you wish and apply with OK.

Either assign additional names to the sensors or end the menu with "Set."

ST 20/ 25

ST 30

DECT 30

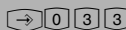
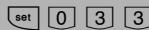

Notes

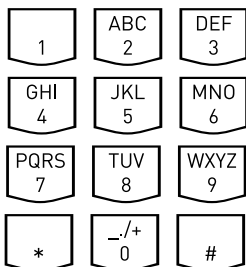

Entering the name with the number keys:

Press numbers 1 to 0 repeatedly,

Example: 2 = A
22 = B
222 = C
2222 = 2

press "next" to go to the following entry or return to the previous entry after time, characters can be overwritten

delete blinking character

delete entire entry

Using  you can switch between upper and lowercase letters. The display shows either ABC or abc.



AIS-Modul 400

Sensor Test

Programming

The sensor test is active for 15 minutes; the "Stop" key ends the test.
During these 15 minutes you have the option of testing the sensor functions. During a sensor test, the triggered sensor calls only the telephone that initiated the test.

ST 20/ 25

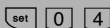

ST 30



DECT 30



Sensor Activation using the function key

You have the option of setting up a freely programmable function key dedicated to the sensors.

Setting up the sensor function key

Programming

Select the function key to be modified
"S" for sensor key or page to the desired
function

Confirm selection

Using the numeric keypad, enter the internal
calling number assigned to the sensor for
which you are setting up the key and confirm
with OK. The key is configured.

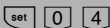

oder



oder



oder



Sensor Activation / Deactivation using the function key

Press the "sensor" key

If you have set up an alarm code, the system telephone display will ask you to enter an alarm code.

You have already defined this alarm code in TK Suite Set under "Security features codes – alarm code." Enter the alarm code using the keypad.

Select whether the sensor(s) should be activated / deactivated and confirm with OK. The LED on system telephones equipped with LED's will blink when this function is activated.

AIS-Modul 400

Activating / Deactivating the Sensor using the Telephone.



Pick up handset

* 4 7 4

Code for sensor activation



Enter extension number for the sensor



0 = off
1 = on



Replace handset

Please listen to resulting messages such as "Please enter the PIN code," or "The PIN code is incorrect."

When asked for the PIN code, enter the alarm code.

If you have incorrectly entered the PIN code, you must repeat the procedure in order to activate / deactivate the sensor.

Querying the Sensor using the Telephone



Pick up handset

* 4 7 5

Query code for sensor status



Enter extension number for the sensor
You will receive a message (e.g., "Sensor input 1 has been activated") with the current status of the selected sensor.



Replace handset

Activating and deactivating the sensor, as well as querying can also be performed using the external switchbox. Refer to the TK system operating instructions for the exact use of the switchbox.

AIS-Modul 400

Disable the Wake Up Call



Enable the Wake Up Call

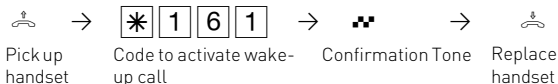

Answer a Wake Up Call

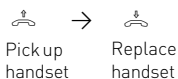

Snooze Function

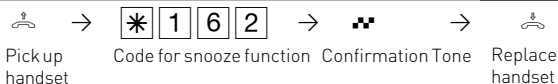

After initiating the “snooze” function, the wake-up alarm will be repeated every 10 minutes for an hour, unless you deactivate it.

Querying a Wake Up Call

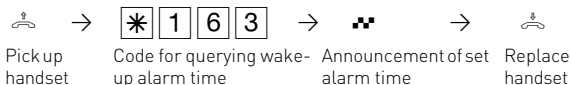

To Set a Wake Up Call

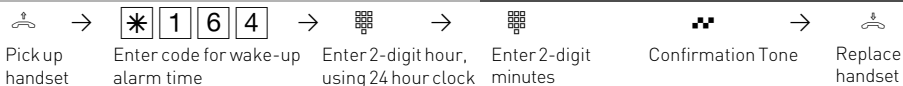

AIS-Modul 400

Load Wavefiles into ST 30 with TAM Module

It is possible to load wave files which can be used as ring tones or announcements in your ST 30 with answering machine module. For this you will need the AIS Configuration Tool from Version 2.3.

- Click on the Button ST 30 with Answering Machine Module
- Click on the Button Extension Number TAM Module
- Enter the extension number of the answering machine which you want to allocate a wave file as ringing tone.
- Select a ringing tone
- Click with a right mouse click, a context menu will open.
- Allocate a wave file to the ringer.
- Click again with a right mouse click a context menu will open
- Click onto 'Send to Module'

The wave file is now stored in you phone.

Please note that the SK Suite Server application has to be disabled before you can send files into the telephone system using the AIS Configuration Tool.

In the same way you may also load answering machine announcements into the telephone.

AIS Configurator - ST 30 with A-Module 30

AGFEO AIS Configurator

unbenannt.pfl <http://www.agfeo.com>

New Open Save As

AIS Module ST 30 with A-Module 30

Extension No. A-Module:

ST30 A-Module - internal Number : 20

#	Name of item/Application	Wave file (volume)	Wave files (A-Module)	Accompanying commentar...
1	Greeting announcement first number	No files are assigned to se...	--:--	
2	Greeting annou	o Pick wave file(s)	se...	--:--
3	Announcement	o Listen to wave file	se...	--:--
4	Announcemen	o Remove item(s) from list	se...	--:--
5	Rufrythmus 1.	o Add/change commentary	--:--	
6	Rufrythmus 2	o Send to A-Module	--:--	
7	Rufrythmus 3	o Delete in A-Module	--:--	
8	Rufrythmus 4	o Read out from A-Module	se...	--:--
9	Rufrythmus 5	o Check data in A-Module	se...	--:--
10	Ring tone /Rin	o Play A-Module Wave at ST30	se...	--:--
11	Ring tone /Rin		se...	--:--
12	Ring tone /Rin		se...	--:--
13	Ring tone /Rin		se...	--:--
14	Ring tone /Rin		se...	--:--

Send complete profile Complete data check of A-Module

Time left in A-Modul --:--

Declaration of Conformity

EU-Konformitätserklärung

EC-Declaration of Conformity
CE-Déclaration de Conformité

Der Hersteller: AGFEO GmbH & Co. KG

The Manufacturer:
Le Constructeur:

Adresse: Gaswerkstr. 8
D - 33647 Bielefeld

Address:
Adresse:

Erklärt, dass das Produkt: AIS-Modul 400

Declares that the Product:
Déclare que le Produit:

Type: Einsteckmodul

Model: AIS-Modul 400

Components: -----

die grundlegenden Anforderungen gemäß Artikel 3 der nachstehenden EU-Richtlinien erfüllt:

meets the essential requirements according to article 3 of the following EC-Directive:
est conforme aux exigences essentielles d' article 3 de la Directive CE:

Richtlinie 1999/5/EG des Europäischen Parlaments und des Rates vom 09. März 1999 über Funkanlagen und Telekommunikationsendeinrichtungen und die gegenseitige Anerkennung ihrer Konformität

Directive 1999/5/EC of the European Parliament and of the Council of 09 March 1999 relating to radio and telecommunications terminal equipment, including the mutual recognition of their conformity
Directive 1999/5/CE du Parlement européen et du Conseil du 09 mars 1999 concernant les radio et équipement terminaux de télécommunications, incluant la reconnaissance mutuelle de leur conformité

und dass die folgenden harmonisierten Normen angewandt wurden:

and that the following harmonised standards has been applied:
et que les standards harmonisés suivants ont été appliqués:

EN 55022/2000
EN 55024/2001

Bielefeld, 18. August 2003

Ort und Datum der Konformitätserklärung

Place and date of the declaration Lieu et date de la déclaration

Phone : +49(0)5 21 44 70 9-0
FAX : +49(0)5 21 44 70 9-50



Name und Unterschrift
Name and Signature Nom et Signature

Copyright

Copyright 2004 AGFEO GmbH & Co. KG
Gaswerkstrasse 8
D-33647 Bielefeld

We reserve all rights for this documentation; this particularly applies to patent applications and registration of functional models.

Neither the entire documentation nor parts thereof may be modified without our express written approval; in addition, the documentation may not be translated into a foreign language or computer language no matter what form without our express written permission. This also applies to electronic, mechanical, optical, chemical or other media. Trademarks and company names used in this document are subject to the rights of the respective companies.

Technical modifications

AGFEO GmbH & Co. KG reserves the right to modify illustrations and data without prior notification. This documentation was created with care and is regularly updated. Despite due care, we do not assume responsibility for inaccuracies and typographical errors. All identified errors will be corrected in future editions. We would appreciate notification of any errors in this documentation.

AGFEO has obtained Copyright Free Music and messages from

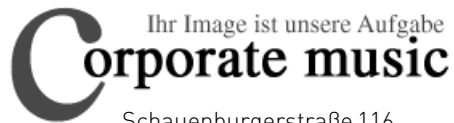

Schauenburgerstraße 116
24118 Kiel
Tel.: +49 (431) 5606370
Fax: +49 (431) 5606371

info@on-hold.de
<http://www.on-hold.de>



Ident no. 1100353

Subject to change without notice. No liability
can be accepted for errors contained in this
document.

Printed in Germany

0049

AGFEO GmbH & Co. KG

Gaswerkstr. 8

D-33647 Bielefeld

Internet: <http://www.agfeo.de>